

PRODUCT COMPLIANCES

Product tested and complies to:

AS/NZS 60598.2.1:1998, AS/NZS 60598.1:2003, AS/NZS 61347.1:2002, IEC 61347-2-13:2006, IEC 62031: 2012, EN 55015:2009, EN 61547:2009, EN 61000-3-2:2009, EN 61000-3-3:2008

INSTALLATION INSTRUCTIONS



Model: Oyster LED

Thank you for purchasing this SIMX Oyster Led. This luminaire is suitable for outdoor use and requires a 220V-240V AC power supply. Please read this manual thoroughly before installation and retain for future reference.



TECHNICAL SPECIFICATIONS

Power source	220-240 VAC
Power frequency	50/60Hz
LED type	SMD2835 4000K
Working temperature	-10°C to + 40°C
Working humidity	<95% RH
Ingress Protection	IP66
Construction	Polycarbonate UV stabilised, stainless steel brackets

Model	Oyster LED Description	Luminous Flux	Rated Load
LHT0222	300mm Round - Black	780lm	0 .07A 14W
LHT0223	300mm Round - Cream	780lm	0 .07A 14W
LHT0224	350mm Round - Black	1150lm	0 .095A 20W
LHT0225	350mm Round - Cream	1150lm	0 .095A 20W
LHT0226	400mm Round - Black	1500lm	0 .115A 24W
LHT0227	400mm Round - Cream	1500lm	0 .115A 24W

! IMPORTANT

This product is suitable for use only with a supply voltage of 220-240V AC 50/60Hz.

All electrical work must be carried out in accordance with local and national electrical codes as applicable. We strongly recommend that this light fitting is installed by a registered electrician.

Always switch power off prior to installation. A means of mains power isolation must be installed on the circuit for the purpose of safe access for any internal cleaning, recalibration, or maintenance.

This light fitting is not intended for use by persons (including children) with reduced physical, sensory or mental capabilities, or lack of experience and knowledge, unless they have been given supervision or instruction concerning use of the appliance by a person responsible for their safety. Young children should be supervised to ensure that they do not play with the appliance.

Any changes or modifications made or attempted to this product, without the prior written approval of the manufacturer, will void any and all stated warranties.



Distributed by: Simx Limited

Ph: +64 9 259 1660 | Technical Support Ph: +64 9 259 1662

Email: sales@simx.co.nz | www.simx.co.nz

Simx reserves the right to alter technical specifications without prior warning

Pub1248 iss01 04/14

INSTALLING YOUR LED

This light fitting is rated to IP66 and suitable for permanent outdoor use. Ensure the desired location does not exceed this rating. Switch off the power supply before commencing electrical work.

We strongly recommend this light fitting is installed by a registered electrician.

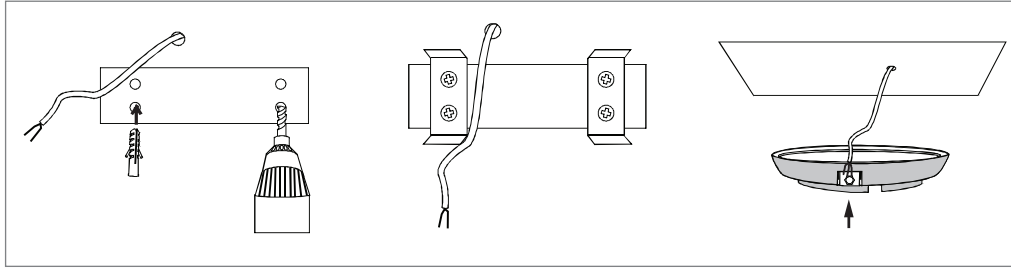

Fig A

Using the template provided mark the hole locations on the mounting surface. Drill holes through the template to suit the mounting screws supplied. In the same location drill the power cable entry hole. Firmly secure the fixing brackets to the ceiling with the screws provided. (Fig A)

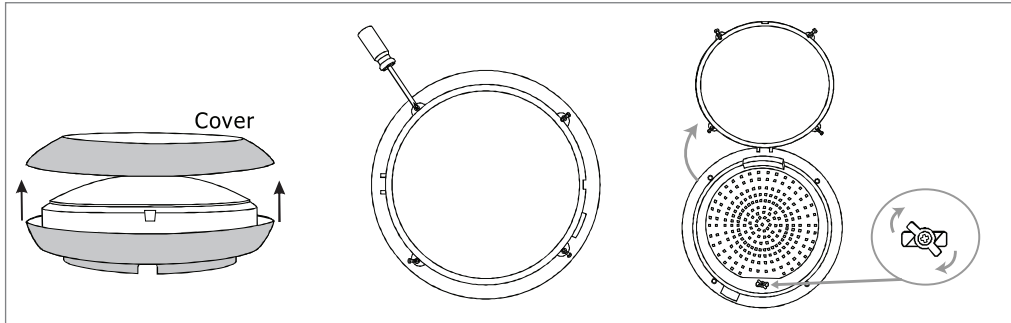

Fig B

Unclip the front cover and unscrew the white diffuser and locate the mounting holes for the power cable under the hinged section (Fig B)

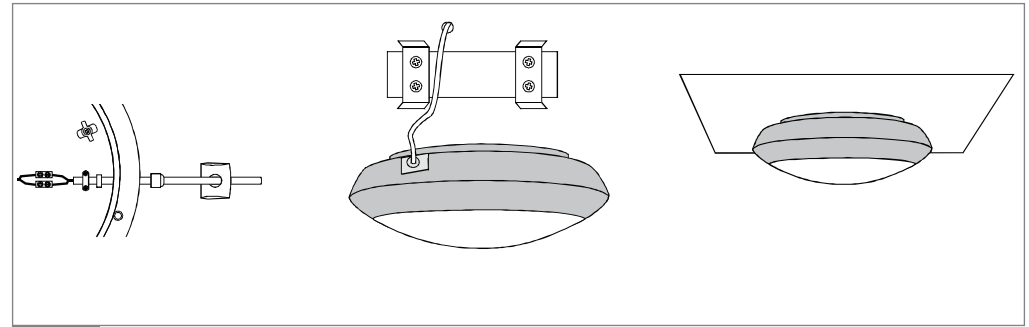

Fig C

Locate the power cable entry on side of the unit and slowly draw the power cable through the gland on side of the unit.

Wire the cable to the terminal block, ensuring that polarity is maintained (Brown is L and Blue is N). Failure to do this correctly may result in damage to the unit.

Secure the cable into position using the saddle clamp provided, do not over tighten.

Tighten external gland and refit the black plastic cable cover.

Secure LED panel and carefully secure the diffuser and cover into position (use locator lug inside cover to align correctly).

Clip luminaire into position on the fixing brackets already installed. (Fig C)

Check all work before reconnecting the power supply.

To maintain IP rating, correct cable for gland is round core 6mm twin.

MANUFACTURERS EXTENDED WARRANTY

This product is guaranteed by SIMX Ltd for 36 MONTHS from the date of purchase against faulty materials or workmanship which affects its designed ability to operate. During this period if the product has a defect of this nature it will be repaired or replaced free of charge by SIMX with the same item, or a similar item, or a similar one of higher specification. ON CONDITION THAT:

The buyer returns it to the seller from whom it was bought, freight paid.

The product has been bought by the user. ie a receipt/sales invoice is produced as proof of purchase.

The product has not been misused or handled carelessly, installed in anyway contrary to the installation instructions, or installed in any unusually exposed or harsh environmental conditions.

This guarantee excludes liability for discolouration of paint or plastic, or any user replaceable parts. It does not confer any rights other than those expressly set out above and does not cover any claims for consequential loss or damage.

Our Goods come with guarantees that cannot be excluded under the Australian and New Zealand Consumer law. You are entitled to a replacement or refund for a major failure and for compensation for any other reasonably foreseeable loss or damage. You are also entitled to have the Goods repaired or replaced if the Goods fail to be of acceptable quality and the failure does not amount to a major failure.