

DATA SHEET

AOL WL 100 OP 800 830 MD WH

Item number EL10750700
GTIN 4015120750700



Technical data

GENERAL	
Device category	Wall light
Remote controllable	–
Conformity	CE, EAC, RoHS, WEEE
Warranty	3-year
ATTACHMENT	
Installation type	Surface mounting
Installation position	Wall
Type of connection	Screwed terminal
Connectable wire cross section	1,50 – 2,50 mm ²
HOUSING	
Dimensions	Length 205 mm x Width 104 mm x Height/Depth 143 mm
Weight	508 g
Material	Aluminium and UV-stabilised plastic
Protection type	IP55
Permissible ambient temperature	-25 °C...+50 °C
Colour	white, similar to RAL 9016
Glow wire test in accordance with IEC 60695-2-10	650 °C
ELECTRICAL VERSION	
Control system	ON/OFF
Protection class	II
Nominal voltage	230 V AC / 50 Hz
In-rush current	100 A / 200 µs

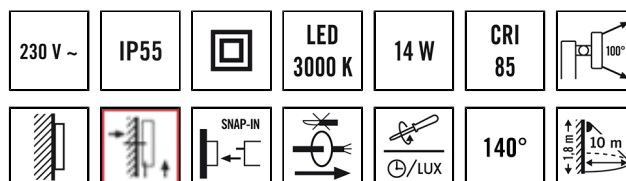

Product description

- Automatic light with built-in motion detector
- Design lamp made of die-cast aluminium and plastic
- 14 W, light colour approx. 3000 K warm white
- 140° field of detection, range up to 10 m at an installation height of 1.8 m

Offers special product features like:

- Integrated motion detector

Leakage current	0,01 mA
Stand-by consumption	0.5 W
LIGHT	
Diffusor	opal
Light emission	direct
Beam angle	90 °
Flicker factor	<10 %
Rated output P	10 W
Luminous Flux (light)	900 lm
Luminous efficacy	90,00 lm/W
Colour temperature	3000 K
Colour rendering index Ra	> 80
L70B10 lifetime at 25 °C	80000 h
Life time L70B50 at 25 °C	100000 h
Life time L80B10 at 25 °C	50000 h
Life time L80B50 at 25 °C	65000 h
Life time L90B10 at 25 °C	25000 h
Life time L90B50 at 25 °C	30000 h
Energy efficiency class	A++ to A
SENSORS	
Detection angle	140°
Detection range diagonally	10 m
Detection range head-on	2 m
Field of detection	122 m ²
Recommended installation height	1,8 m
Level of brightness	5 - 1000 lx

DATA SHEET

AOL WL 100 OP 800 830 MD WH

Item number **GTIN**
 EL10750700 4015120750700

Scale drawing

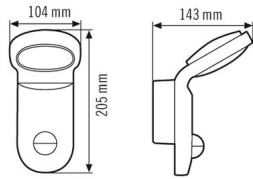

Field of detections

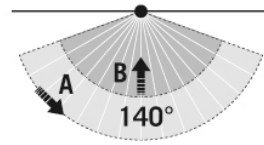

Detection range

Diagonally (A)	10 m
Frontal (B)	2 m

Light distribution

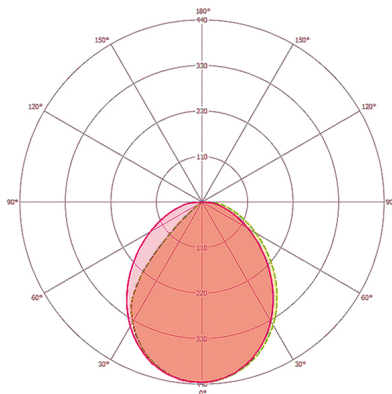

Circuit diagram

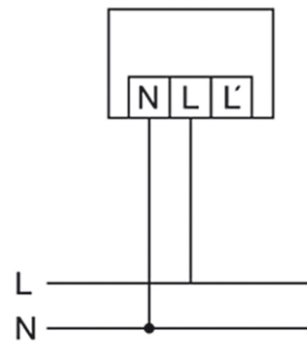

Standard operation

Circuit diagram

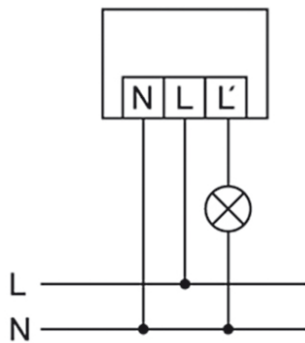

Standard operation with additional connection of external loads