

## Manrose “Pro-Series Heat ‘n Vent 2” (FAN0940)

Installation Instructions and Hole-cutting Template: 390mm x 220mm (Note: Please read these instructions thoroughly before commencing installation.)

### FEATURES

**Ventilation Fan;** The Pro-Series Heat ‘n Vent 2 is designed to be, and should be, ducted to the outside of the house to fully comply with the requirements of the NZ Building Code and certain Australian State Regulations. The ducting and exterior grille is supplied as an integral part of this product. As the fan is a centrifugal design, designed to create pressure and push air through longer ducting runs, extra lengths of ducting may be added when required. (3 metres of the same type of ducting may be purchased by quoting order code **DCT0329**.) The fact that the fan is a centrifugal design allows the ducting diameter to be reduced to a small size (120mm diameter) which is more easily routed through the confines of ceiling spaces and yet still achieve airflow rates suitable for bathroom steam and moisture extraction. In addition, the horizontal outlet of the duct ensures that the Pro-Series Heat ‘n Vent 2 can be mounted within flat or low-pitched roofs and between floors when necessary. **Heat Lamps;** The Pro-Series Heat ‘n Vent 2 hard-glass infra-red heat lamps are designed to provide instant heat when you stand directly underneath the lamps, heating you and not relying on having to heat the surrounding air. As such, they need only to be turned on when you are in the room. As a very important safety feature, every one of the lamps has been pre-tested. Each individual lamp has been heated to its maximum operating temperature and then sprayed with ice-water to ensure that there are no flaws in the construction. Replacement heat lamps can be ordered on code **LHT0081** and LED lamps on **LHT0211**.

### IMPORTANT CONSIDERATIONS BEFORE INSTALLING

**Locating the Pro-Series Heat ‘n Vent 2;** A few minutes planning can make a vast difference to the installation time and also to your satisfaction with the functioning of your Pro-Series Heat ‘n Vent 2. The unit should be fitted close to the area where the steam and condensation is generated but must not be mounted directly above a shower or bath. Care must be taken to comply with the relevant electrical wiring standards and the requirements for damp areas (NZ ECP 51 or AS/NZS3000:2018). The Infra-red heat lamps are most effective when you are standing directly beneath them, so generally the unit would be mounted outside the shower cubicle where you would stand to dry yourself. This is also the area where the main amount of steam is present, hence the most effective area for the fan. For the fan to work efficiently, replacement air of a volume equivalent to what is being extracted must be able to enter the room. In general this air would be drawn under the door, or through a slightly open window. The flow of the make-up air should be such that it passes through the steam to the fan, allowing the steam and moisture to be collected on the way. If the room is air-tight, the fan will function poorly. In this case thought should be given to installing a door-vent (Order Code: FAN0159) or a 15mm under cut door. Do not mount the unit on a sloping ceiling.

**INSTALLATION (Note: All wiring must be carried out by a registered electrical contractor. A means for disconnection from the supply must be incorporated in the fixed wiring in accordance with the wiring and regulations).**

- 1) Select the mounting position for the unit. Before commencing any cutting check in the ceiling space that there are no obstructions such as ceiling joists and that there is sufficient height clearance for the housing. From the underside of the ceiling there should be a minimum of 240mm overall height to the underside of any ceiling materials (50mm clearance above the housing is allowed for in this measurement to provide air circulation around the housing). Check that the electrical wiring can be routed from the wall switches to the mounting location. Install the wiring and switches per the wiring diagram. There are three separate controls - fan, light and heat lamps.
- 2) Check that it is possible to route the ducting from the unit to the outside of the house - this will generally be to the soffit but can also be to a wall outlet location. (If the wall outlet is located in an exposed location you may need to purchase a louvre outlet grille to stop wind-driven rain entering the ducting (**DCT0041**). Alternatively you may seal the ducting to the grille spigot using a suitable silicon sealant. The ducting is waterproof and a small amount of water in the ducting will not be harmful). Cut a 125mm diameter hole in the soffit for the ducting outlet.
- 3) Use this template to mark the hole outline on the ceiling. After cutting the hole the ducting can be routed from the housing location to the hole in the soffit. Stretch the ducting out as required. Approximately 50mm of ducting should be pulled through the ‘discharge hole’ in the soffit. This will facilitate connection of the grille later. **NOTE:** Excess ducting should be removed to maximise performance. The ducting should be as straight as possible with the minimum number of bends. Make the ducting connection to the outlet, ensuring that excess ducting is removed at this point.
- 4) You will note that a back-draught shutter may be included with the unit and mounted within the outlet. Under normal circumstances it is NOT necessary to use this device and it will reduce the air flow performance of the unit. Please **REMOVE AND DISCARD**. If the duct outlet is exposed to prevailing winds or you have particular concerns about back-draught, leave the shutter in place.
- 5) Remove all lamps from the unit. Unclip the two internal fascia-retaining springs inside the housing. Remove the fascia. It is possible and preferable to make the ducting and electrical connections prior to positioning the housing in the hole. When positioning the housing into the hole, pull the two spring retaining clips into the housing before inserting, to avoid damaging the plaster-board. The clips are designed to retain the housing in standard 9-12mm ceiling linings. For thicker material it may be necessary to use the screw-mounting option to fasten the housing. Replace the fascia and retaining springs, re-insert the lamps. Ensure the lamps are tightened sufficiently to make good electrical contact. **DO NOT FORCE OR OVER-TIGHTEN**. If replacing, use only 275W hard-glass lamps. The LED lamp should be GU10.

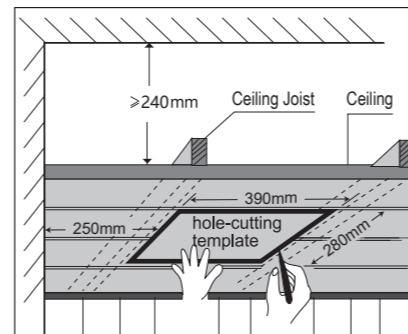

(1)

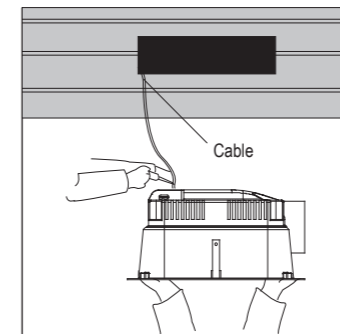

(2)

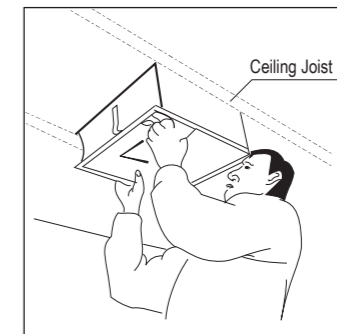

(3)

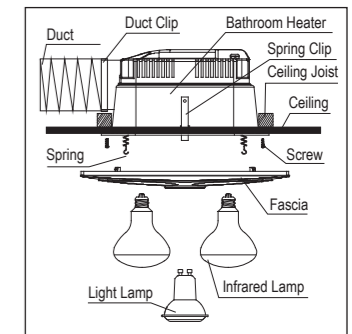

(4)

**N.B: Replacement with lamps other than those specified may result in damage to plastic components. In this case the damage shall not be covered by the product warranty.**

- 6) Remove the grille insert from the discharge grille and fasten the duct to the grille spigot. Fasten the grille into position and clip the grille insert back into position.
- 7) Test all functions.

### ELECTRICAL WIRING

**Note;** The requirements for mounting in damp areas as detailed in AS/NZ Electrical Safety Standard

**Note;** The supply connection should be made using cable with an installation temperature rating of 115 or higher.

The Pro-Series Heat 'n Vent 2 requires a 230/240 volt, 50Hz supply.

**All electrical work must be carried out by a registered electrical contractor.**

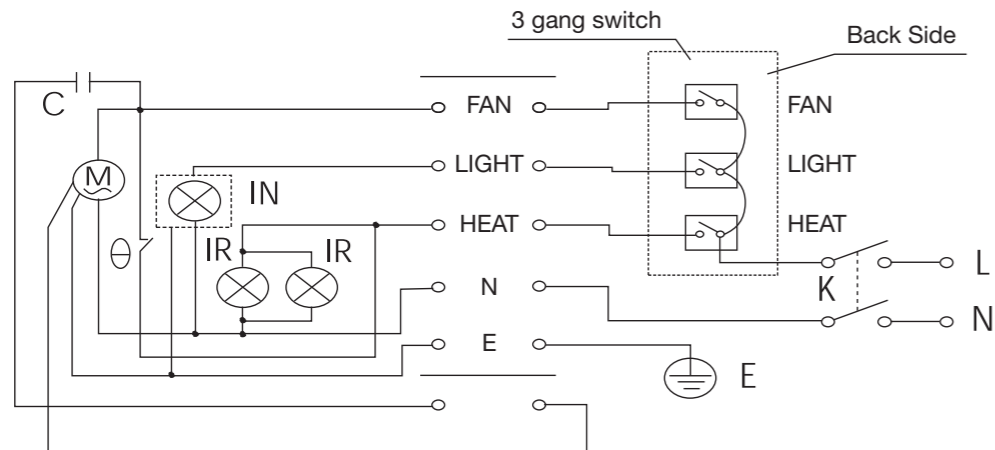

M: Motor C: Capacitor IR: Heat Lamp IN: Light Lamp  
K: All-pole disconnection Switch ⊖: Heat Protector

### WARRANTY

This product is warranted against failure for a period of five years (excluding LED light bulb and infrared heat lamps). Either parts or the complete product may be replaced at the sole discretion of Simx Ltd. The infrared heat lamps are warranted for a period of two years against electrical failure. (accidental breakage excluded). The LED lamp is excluded from these warranties. No liability is accepted for any consequential losses arising from misuse or incorrect installation or operation of this product. The product must be installed according to the installation instructions. The product must not be altered or modified in any way. Proof of purchase date must be provided for any claim to be recognised. The benefits conferred by this warranty are in addition to any other rights or remedies available under the Consumer Guarantees Act or Fair Trading Act.

### CAUTIONS

Ceiling insulation **MUST BE KEPT WELL CLEAR** of the fan housing (at least 100mm) to allow adequate air circulation. **ENSURE THE HOUSING IS NOT COVERED AND THAT ANY VENT HOLES ARE UNOBSTRUCTED.** The heat lamps are designed for intermittent operation and should not be left on for extended periods without the fan running. Ensure the unit is switched off before changing any lamps or carrying out any maintenance. Ensure the lamps have cooled before handling. Ensure that the grille openings do not become blocked with dust or dirt. The appliance is not intended for use by young children or infirm persons without supervision. The switch provided must be incorporated in the fixed wiring in accordance with the wiring rules in order to provide a means of disconnection from the supply.

Pro-Series Heat 'in Vent 2 is distributed by **Simx Ltd.**

1 Haliday Place, East Tamaki, Auckland; PO Box 14347, Panmure, Auckland, New Zealand

Customer Support: NZ :- 09 259 1660

### CLEANING

The unit can be periodically cleaned as required. A damp cloth can be used for this purpose. Ensure the Heat lamps, LED light bulb and fan are not operating and the Heat lamps are not hot. Gently unscrew the heat lamps to remove them if required and then clean only the front surface of the fascia. There is no need to remove the fascia of the unit from the rest of the body. This final operation should only be done by an electrician.