

Please ensure these instructions are read thoroughly before commencing installation and that all documentation is left with the home owner on completion of installation

CAUTION

- Before use, please check that the supply voltage and that of the appliance are the same (see product rating label).
- All wiring and wiring connections must comply with national wiring rules and regulations.
- Any changes or modifications made or attempted to this product, without the prior written approval of the manufacturer, will void any and all stated warranties.
- This appliance is not intended for use by persons (including children) with reduced physical, sensory or mental capabilities, or lack of experience and knowledge, unless they are capable of, and have been given supervision or instruction concerning use of the appliance by a person responsible for their safety.
- Children should be supervised to ensure that they do not play with the appliance.
- In case of damage to the supply cord, switch off the device and do not tamper with it. Damaged supply cords must only be repaired or replaced exclusively by the manufacturer or by an appointed representative. Failure to comply with the above may endanger the safety of people and cause possible damage to the whole system.
- Exhaust fans may adversely affect the safe operation of appliances burning gas or other fuels (including those in other rooms) due to back flow of combustion gases. These gases can potentially result in carbon monoxide poisoning. After installation of an exhaust fan such as a partition fan or a duct fan the operation of open flued gas appliances should be tested by a competent person to ensure that back flow of combustion gases does not occur.

ELECTRICAL CONNECTION

NOTE: Junction box supplied is suitable for internal use and below roof installation (inside the building)

- Cut the roof flashing on the 150/160 marking and fit to the rigid duct before commencing (see separate installation sheet detailing this).
- For below roof terminations the motor lead exit hole should be as far down the rigid duct as is practical – allow enough lead to protrude from the duct as is required for termination. After fitting the roof flashing, drill an 8mm hole at a suitable point in the rigid duct and fit the supplied rubber grommet. The motor lead can then be passed through the grommet to the outside of the rigid duct.
- The assembly can now be placed in position in the roof penetration (see instructions on page 3). Once the assembly has been fastened to the roof by the roof flashing fastening procedure, the electrical connections can be made. The junction box can be fastened to the rigid duct if necessary.



Fig 1



Fig 2

Junction box is supplied for the following cowls and kits with an inline axial EC fan:
FAN0531 / FAN0532 / FAN0533 / FAN0534 / FAN0739 / FAN1009 / FAN1060 / DCT0189

Junction box is supplied for the following cowls and kits with an inline centrifugal fan:
FAN0529 / FAN0530 / FAN0535 / FAN0740 / FAN0967 / FAN1002

- You may find it more convenient to pull the whole assembly down as far as possible in the roof flashing to carry out the terminations (Fig 1). Once completed, the assembly can then be pushed back up through the Dektite. Ensure that a visual check is made above the roof afterwards to check that the roof flashing is sealing correctly around the rigid duct (Fig 2). Once the terminations are completed the rigid duct can then be fastened to a rafter or purlin with the supplied clamp for rigidity. Ducting connections can then be made.
- Please ensure that the rigid duct extends far enough above the roof line so that rain water cannot splash back into the open fan cowl.

TECHNICAL



Duct (mm)	Fan Type	Max. Fan Watts (W)	Max. Fan Pressure (Pa)	Free Air Fan Performance		Specific Fan Power (W/l/s)	Sound dB(A)	Switching
				(l/s)	(m³/hr)			
150	Centrifugal	70	320	153	550	0.46	62	Standard
150	EC Axial	18	91	105	380	0.17	38	Standard

REGULATIONS AND STANDARDS

New Zealand Building Code and Healthy Homes

The following two category requirements have been established for mandatory extraction ventilation in New Zealand.

The New Zealand Building Code for New Building Consents

The building regulatory system sets out a framework to promote good quality decisions being made during the Building Consent process. The legislation and regulations work together, as the building regulatory system. The functional clauses of the NZ Building Code are grouped and described by a letter and number. Clause G of the NZ Building Code covers services, with G4 setting out the performance requirements for ventilation. The Building Code is enshrined in law. The New Zealand Building Code, G4, has been changed. This is supported by Acceptable Solution G4/AS1 Fourth Edition that specifies mechanical ventilation in accommodation units that contain cooktops, showers and baths.

Residential Tenancy Regulations to the Healthy Homes Standards

Residential Tenancy Regulations for rental properties only is changing to the Healthy Homes Standards, sub part 4 - Ventilation Standards.

Complying with the Acceptable Solution G4/AS1

To comply, the mandatory mechanical extract system must deliver minimum airflow rates for the complete installed ventilation system. This means that airflow rates must deliver the airflow after resistance of the ducting, internal and external grilles, as well as all other accessories, such as backdraught shutters, are included.

Fan selection is important as some types are far better at overcoming ducting system pressure drops.

Additionally, the quality of the ducting system installation can be all important. Rigid duct systems (see page 102) are best as they are the most efficient. Good installation practice is vital for flexible duct systems.

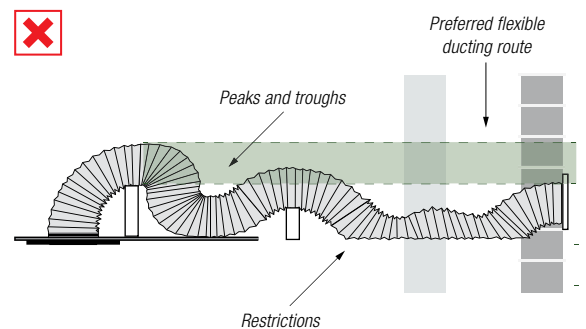
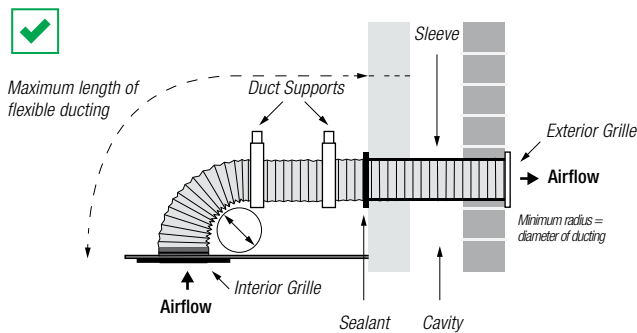

Choosing the Right Fan to Comply

Fans cannot be selected on the basis of free-air performance only. Fans must now be selected on the basis of the complete installed system performance for a designated room as per the table below.

Room	Airflow Rate (min.)	
	Intermittent	Continuous
Toilet ¹⁾	25 l/s	10 l/s
Bathroom/shower	25 l/s	10 l/s
Laundry ²⁾	40 l/s	-
Kitchen	50 l/s	12 l/s

1) Toilets only require ventilation if they have no openable windows

2) Simx recommends 40 l/s for laundries with unvented non-condensing tumble dryers as covered in AS 1668: Part 2 2012

Recent unregulated extract fan practices in New Zealand has trended to basic, low pressure axial fan products, as installed system performance has not been defined for independent inspection testing and compliance signed off by local authorities.

Bathroom

25 l/s

		Metres of Ducting									
		1	2	3	4	5	6	7	8	9	10
No. of Bends	1										
	2										
	3										
	4										
	5										

Fan Selection

Hyper150 EC

Mixflo 150

Kitchen

50 l/s

		Metres of Ducting									
		1	2	3	4	5	6	7	8	9	10
No. of Bends	1										
	2										
	3										
	4										
	5										

Blue Jet

WIRING CONNECTIONS

For inline axial EC fan models (no capacitor):
 FAN0531 / FAN0532 / FAN0533 / FAN0534
 FAN0739 / FAN1009 / FAN1060 / DCT0189

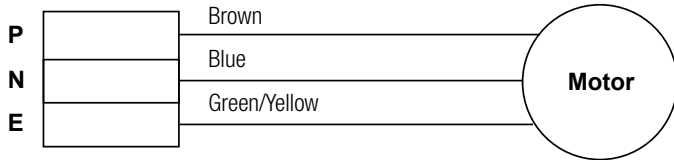

For inline centrifugal (3 speed) fan models:
 FAN0967

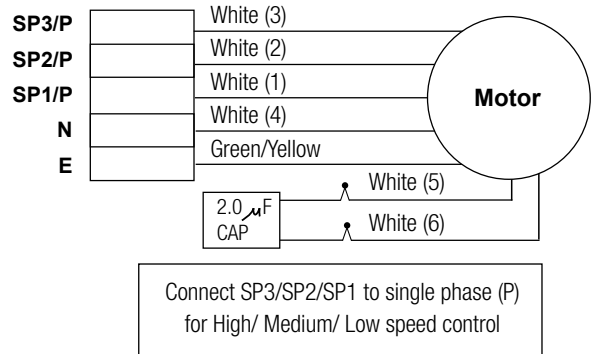

For inline centrifugal fan models:
 FAN0529 / FAN0530 / FAN0535 / FAN0740

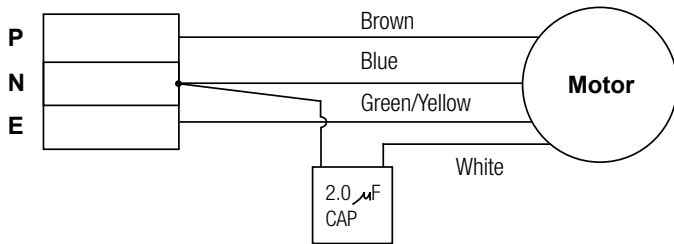

For inline centrifugal (3 speed) fan models:
 FAN1002

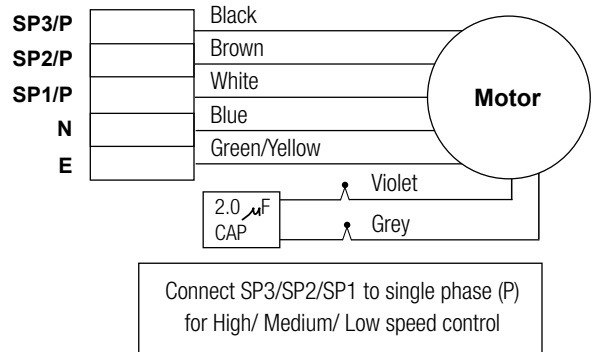

TYPICAL INSTALLATION

Fasten tube to roof truss or rafter using clamp bracket supplied.
 Tube/cowl must be mounted vertically to ensure weatherproofing

Flexible ducting connects directly to the bottom of rigid duct. Cut any excess length of ducting off before connecting.

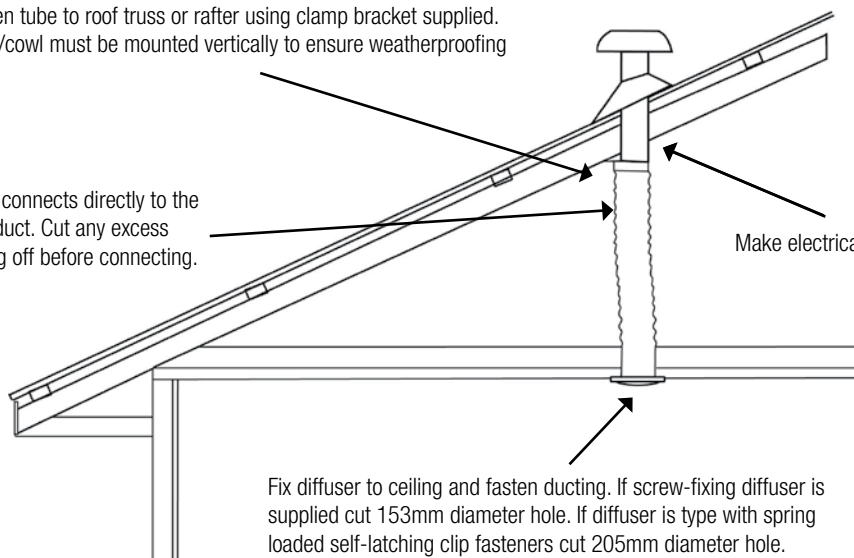

Fix diffuser to ceiling and fasten ducting. If screw-fixing diffuser is supplied cut 153mm diameter hole. If diffuser is type with spring loaded self-latching clip fasteners cut 205mm diameter hole.

INSTALLATION



Cut the pliable roof flashing sleeve where indicated on the sleeve for the relevant tube size: 150/160mm

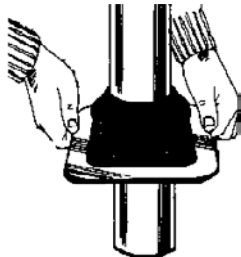

Slide the roof flashing down over the tube. Water can be used as a lubricant.

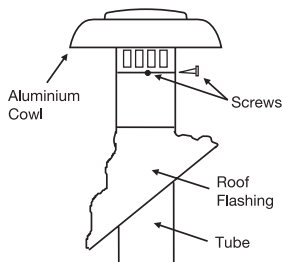

Position the top end of the tube into the cowl. The top edge should sit 20mm inside the cowl. Drill through the three pilot holes and screw the cowl to the tube.



You can now proceed to the actual roof installation. Cut a neat hole in the roofing material with minimal clearance for the tube. Insert the tube through the hole. Apply a neutral cure silicon sealant on the underside of the flange. Turning the flexible flange back makes this simple.

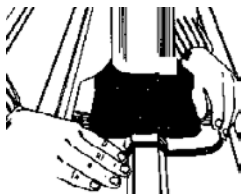

Press the roof flashing into the contours of the roof configuration.

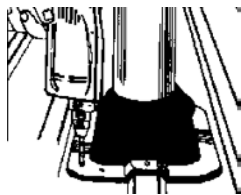

Fasten the roof flashing to the roof using the screws supplied (Hex/slot head - 10 pcs). Drill a 5mm clearance hole in the flange for each screw. The screws can be driven into the roof without the need for a pilot drill hole, or use a 2.5mm drill. Fit the fasteners progressively outward in opposing pairs to avoid gaps. Do not use unapproved fasteners (check roofing manufacturer recommendations). Screws supplied are: AS3566.1 1990 Class 3

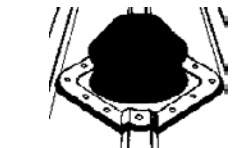

In certain applications it may be advantageous to install the flashing on the **diamond** or bias. This particular installation method is especially suitable when having to seal enlarged holes, for penetrations on steep pitched roofs.

FAN TIMER SELECTION

Please use the FAN2444 fan timer model shown

Do not use old model FAN2444 (with resistor) or either FAN0372 fan timers shown

